

NATIONAL ACADEMY OF ENGINEERING OF THE REPUBLIC OF KAZAKHSTAN

U. JOLDASBEKOV INSTITUTE ON MECHANICS AND ENGINEERING



SIJS 2021 Future Mechanics

2nd INTERNATIONAL JOLDASBEKOV
SYMPOSIUM, KAZAKHSTAN

«FUTURE MECHANICS»
SECOND INTERNATIONAL JOLDASBEKOV SYMPOSIUM

REPORTS DIGEST

1 - 5 MARCH, 2021

ALMATY, KAZAKHSTAN

**ҚАЗАҚСТАН РЕСПУБЛИКАСЫНЫҢ ҰЛТТЫҚ ИНЖЕНЕРЛІК АКАДЕМИЯСЫ
АКАДЕМИК Ө.А. ЖОЛДАСБЕКОВ АТЫНДАҒЫ МЕХАНИКА ЖӘНЕ МАШИНАТАНУ
ИНСТИТУТЫ**

**НАЦИОНАЛЬНАЯ ИНЖЕНЕРНАЯ АКАДЕМИЯ РЕСПУБЛИКИ КАЗАХСТАН
ИНСТИТУТ МЕХАНИКИ И МАШИНОВЕДЕНИЯ ИМЕНИ АКАДЕМИКА
У.А.ДЖОЛДАСБЕКОВА**

**NATIONAL ENGINEERING ACADEMY OF THE REPUBLIC OF KAZAKHSTAN
U. JOLDASBEKOV INSTITUTE OF MECHANICS AND ENGINEERING**



«БОЛАШАҚ МЕХАНИКАСЫ» атты

Екінші Халықаралық Жолдасбеков Симпозиумының

БАЯНДАМАЛАР ЖИНАҒЫ

1-5 наурыз 2021 жыл, Алматы

СБОРНИК ДОКЛАДОВ

Второго Международного Джолдасбековского Симпозиума

«МЕХАНИКА БУДУЩЕГО»

1-5 марта 2021 года, Алматы

REPORTS DIGEST

Second International Joldasbekov Symposium

«FUTURE MECHANICS»

1-5 March 2021, Almaty

*Посвящается 90-летию со дня рождения основателя
казахстанской школы теории механизмов и машин,
академика Джолдасбекова Умирбека Арислановича*

Сборник докладов Второго Международного Джолдасбековского Симпозиума «Механика Будущего», 1-5 марта 2021 года: Электронный. –Алматы, 2021. – 414 с.

ISBN 978-601-08-0953-6

ОРГАНИЗАТОРЫ СИМПОЗИУМА:

НАЦИОНАЛЬНАЯ ИНЖЕНЕРНАЯ АКАДЕМИЯ РЕСПУБЛИКИ КАЗАХСТАН
ИНСТИТУТ МЕХАНИКИ И МАШИНОВЕДЕНИЯ ИМЕНИ АКАДЕМИКА
У.А.ДЖОЛДАСБЕКОВА
КОМИТЕТА НАУКИ МИНИСТЕРСТВА ОБРАЗОВАНИЯ И НАУКИ РЕСПУБЛИКИ
КАЗАХСТАН

ПРЕДСЕДАТЕЛЬ СИМПОЗИУМА:

Бакытжан ЖУМАГУЛОВ

ПОЧЕТНЫЙ ПРЕДСЕДАТЕЛЬ:

Иосиф ВУЛЬФСОН

МЕЖДУНАРОДНЫЙ ПРОГРАММНЫЙ КОМИТЕТ:

Зам. пред.: Тулешов А.К., Казахстан	Кальменов Т.Ш. (Казахстан)
Зам. пред.: Темирбеков Н.М., Казахстан	Калтаев А.Ж. (Казахстан)
Абдраимов Э.С. (Кыргызстан)	Хомченко В.Г. (Россия)
Ахмедов Д.Ш. (Казахстан)	Кошекков К.Т. (Казахстан)
Алексеева Л.А. (Казахстан)	Кыдырбекулы А.Б. (Казахстан)
Альгин В.Б. (Белоруссия)	Мацевитый Ю.М. (Украина)
Алшанов Р.А. (Казахстан)	Молдабеков М.М. (Казахстан)
Амиргалиев Е.Н. (Казахстан)	Надиров Н.К. (Казахстан)
Байгунчечков Ж.Ж. (Казахстан)	Ожикенов К.А. (Казахстан)
Бисембаев К. (Казахстан)	Отелбаев М. (Казахстан)
Чеккарели Марко (Италия)	Пановко Г.Я. (Россия)
Досмухамбетов Т.М. (Казахстан)	Поддубко С.Н. (Белоруссия)
Джамалов Н.К. (Казахстан)	Ракишева З.Б. (Казахстан)
Джомартов А.А. (Казахстан)	Садыбеков М.А. (Казахстан)
Джуматаев М.С. (Кыргызстан)	Сейдахмет А.Ж. (Казахстан)
Джураев А.Д. (Узбекистан)	Смелягин А.И. (Россия)
Глазунов В.А. (Россия)	Тельтаев Б.Б. (Казахстан)
Гуськов А.М. (Россия)	Темирбеков Е.С. (Казахстан)
Halicioglu R. (Турция)	Уалиев Г.У. (Казахстан)
Ибраев С.М. (Казахстан)	Waldemar Wojcik (Польша)
Искаков Ж. (Казахстан)	Евсюков С.А. (Россия)
Иванов К.С. (Казахстан)	Жантаев Ж.Ш. (Казахстан)
Jacek Cieslik, (Польша)	Жаппасбаев У.К. (Казахстан)
Калимолдаев М.Н. (Казахстан)	Джомартов А.Ч. (Казахстан)

ОРГАНИЗАЦИОННЫЙ КОМИТЕТ:

Тулешов А.К. (председатель)	Абдураимов А.
Темирбеков Н.М. (сопредседатель)	Куатова М.Ж., председатель СМУ
Джомартов А.А. (зам. председателя)	Каимов С.Т.
Имангалиев Е. (зам. председателя)	Нурлаев Ж.
Хабиев А. (ответственный секретарь)	Ибраева А.С.
Айдарбекова Ж.Б.	

OPTIMAL SYNTHESIS OF THE UPPER AND LOWER LIMB EXOSKELETON MECHANISMS

¹Ibrayev S.M., ²Sakenova A.M., ²Karim A.T., ²Ibrayeva A.S., ²Amanov B.

¹Joldasbekov Institute of Mechanics and Mechanical Engineering, Almaty, Kazakhstan

²Al-Farabi Kazakh National State University, Almaty, Kazakhstan

e-mail: sayat_m.ibrayev@mail.ru

Аннотация: Рассматривается задача оптимального синтеза механизма экзоскелета верхней и нижней конечностей на основе плоского рычажного механизма, чертящая точка которого генерирует семейство горизонтальных прямых. Предложено аналитическое решение аппроксимационной задачи квадратического приближения, которое позволяет существенно уменьшить размерность численной оптимизации. Предложены две кинематические схемы экзоскелета, соответствующие двум локальным минимумам задачи. Использование предлагаемых механизмов позволяет существенно упростить управление и снизить энергозатраты.

Ключевые слова: экзоскелет верхней/ нижней конечности, регулируемый механизм, аппроксимационный синтез,

Abstract: The problem of optimal synthesis of the upper and lower limb exoskeleton mechanism based on a planar adjustable linkage is considered, the drawing point of which generates a family of horizontal lines. An analytical solution of the least-square approximation problem is proposed, which makes it possible to significantly reduce the dimension of the numerical optimization. Two kinematic schemes of the exoskeleton corresponding to two local minima of the problem are proposed. The use of the proposed mechanisms allows you to significantly simplify management and reduce energy costs.

Keywords: upper/lower limb exoskeleton, adjustable mechanism, approximate synthesis, executive mechanism, open and closed-loop kinematic chain, structural synthesis, linkage mechanism, optimal design, active and passive exoskeleton.

Аңдатпа: Сызу нүктесі көлденең түзулер бойымен қозғалатын жазық иінтірек механизмі негізіндегі қол және аяқ экзоскелетінің механизмін оптимал синтездеу мәселесі қарастырылды. Квадраттық жуықтаудың аппроксимациялық есебінің аналитикалық шешімі ұсынылды, бұл сандық оптималдаудың өлшемін едәуір азайтуға мүмкіндік береді. Тапсырманың екі жергілікті минимумына сәйкес келетін экзоскелеттің екі кинематикалық схемасы ұсынылды. Ұсынылған механизмдерді қолдану басқаруды едәуір жеңілдетуге және энергия шығынын азайтуға мүмкіндік береді.

Түйінді сөздер: қол және аяқ экзоскелеті, реттелетін механизм, аппроксимациялық синтез

Introduction

The design of the executive mechanism (EM) of upper/lower-limb exoskeleton based on planar adjustable linkage generating horizontal straight lines leads to the optimal solution in terms of rectilinear and translational movement of the exoskeleton, ease of adaptation to the surface profile, simplicity of control and energy efficiency. [1-7]. The latter considerations point toward having a single propulsion-actuator on each leg-linkage and additional actuator for adaptation on uneven terrain beneath the robot [3-6]: so one actuator is responsible for foot trace along horizontal path relative to robot cabin, while the secondary one serves for varying the foot height. Thus, the main actuator becomes “gravity independent” (as corresponding partial velocity of foot center is always orthogonal to the vertical axe of gravity action), so no power supply is necessary to maintain weight, unlike traditional exoskeleton design based on open kinematic chain and actuated joints. A large number of linkage design were proposed [6-16], but the main difficulty is to meet the adaptation requirement. Thus, the methods of synthesis of adjustable mechanisms, whose coupler point can approximately trace a variety of horizontal straight lines are found to be very important for simple and reliable exoskeleton design.

However, the main difficulties while synthesizing are related to limitation on the number of prescribed output paths to be traced and the limited number of end-effector exoskeleton positions to be prescribed along the paths [2-4, 16-20]. The number of design parameters is essentially increased, often more than one adjusting parameter are needed and even the additional mechanism is necessary to change the adjusting parameters [21-23]. Mechanism approximate synthesis methods were found to be the most effective concept for synthesizing of adjustable function-generators of both planar and spatial structure [24-26] and later were successfully applied for approximate multi-path generation [27, 28, 20-22, 29-31]. In this article quick and accurate method for leg-linkage optimal design is worked out, when adaptation of the leg on uneven terrain is carried out by single adjustment of the length of two-element link. The analytical solution is obtained for least-square approximation, that allows to decrease essentially the dimensionality of numerical optimization. Unlike the generally used methods, when the adjusting parameter values are supposed to be given by designer, the proposed method allows to determine analytically the adjusting parameter values as well. Therefore, the number of non-linear parameters to be sought by numerical optimization remain the same as in the problem of one-DOF mechanism synthesis. Another advantage of the method is that there are no limitations on the number of desired straight lines and no limitations on the number of prescribed points along these lines as well. Finally, combined with random search technique for initial guess

variation the method allows to define all local minimums of the optimization task. Thus, the method allows to take full advantage from the considered mechanism structure and to find out (“open up”) by this way all functional abilities of the given mechanism scheme.

1. Basic Structural Schemes of the Adjustable Exoskeleton Upper and Lower Limb Linkages for Multiple Straight Lines Generation

The simplest structural schemes of the adjustable mechanisms for multiple path generation could be obtained from four-bar path generator $ABCD$ (Fig.1a) by adding the additional input joint E (Fig.1b-d). Now the mechanism has two degrees of freedom and reproduce not only one prescribed output curve $t-t$, but a family of desired curves t_s-t_s referred to as curve series, s is the parameter of the family. In addition to the main generalized coordinate $q=\alpha$, we have the additional generalized coordinate β_s , that correspond to the input joint E , and β_s serves as the adjusting parameter.

Depending on the location of this additional input joint E we obtain various adjustable mechanism structures, where A is main (primary) input joint and E is the secondary one:

- with adjustable fixed pivot D (Fig.1b), ED is adjusting link;
- with adjustable link length CD (Fig.1c), where the secondary input joint E is responsible to vary the length l_{CD} of link CD ;
- with adjustable coupler BCF (Fig.1d), where the secondary input joint E is responsible to change coupler link lengths l_{BF} and l_{CF} .

For instance, adjustable mechanisms of type 1b for horizontal straight lines generation were obtained in [29, 30], but the results are not applicable for the leg mechanism, since moveable joints lie down the foot center during motion. Adjustable four-bar legs of type 1c was designed by S.M. Song, K.J. Waldron et al. [2, 3] (Fig.2). The link length $l_s=l_{CD}$ of link CD in this mechanism is variable and responsible for leg adaptation on terrain irregularities, however the adaptation range ΔH and accuracy ε are too low. This also applies to the leg mechanism with adjustable coupler length of type 1d presented in [1-3]. A variety of leg linkages with six and more links were proposed later by other authors too [4-16, et al.], but all of them have the same disadvantage.

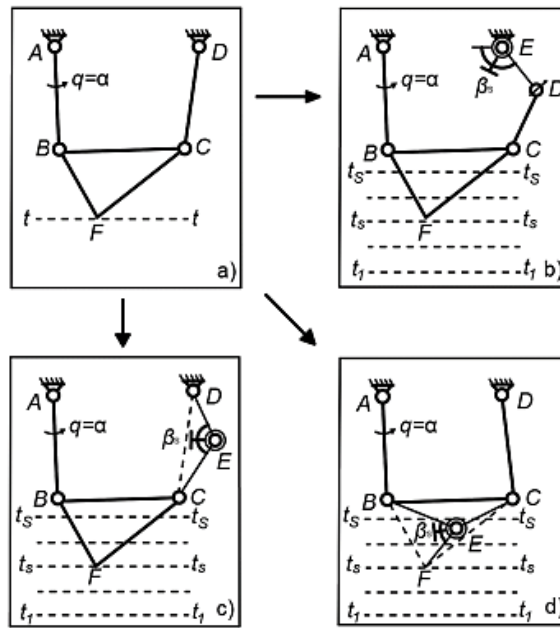

Fig. 1. Four bar linkage (a) and adjustable mechanism structural schemes (b – d)

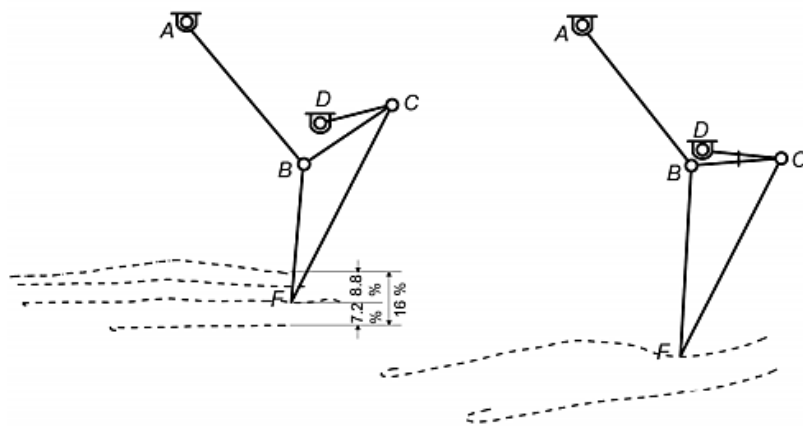

Fig.2. Adjustable four-bar legs of type 1c designed by S.M.Song and K.J.Waldron

In this article we will demonstrate, that both the adaptation range and accuracy can be increased essentially by applying least-square approximation technique of synthesis, as it allows to determine analytically the adjusting chain variables. As the result the number of “non-linear” parameters, sought by numerical optimization, remain the same as by synthesizing of traditional one-DOF path generator, regardless on the number of desired paths to be traced.

2. Analytical synthesis of the adjusting chain

It is well known that synthesis of one-DOF mechanism for path generation can be reduced to binary link (or two-element link) synthesis based on approximate circle-fitting [27, 28, 30]. Let coupler point F of four-bar linkage $ABCD$ (Fig.1a) have to trace planar trajectory prescribed by the large number of N points $F_i, i = 1, \dots, N$, In accordance with the approximate synthesis approach, the

mechanism is considered as being composed of two kinematic chains: dyad ABF , referred to as variable chain, and binary link CD . Specifying the parameters of the dyad ABF and forcing point F to follow the given points F_i we determine the loci $(BF)_i$ of link BF , corresponding to F_i . Then so called “circular point” C is sought on the coupler BF , i.e. point C that approximately trace circle with center D . By the similar way, to synthesize the adjustable mechanism shown in Fig.1c the latter is considered as being composed of the dyad ABF referred to as “variable chain” and dyad CED (Fig.3) referred to as “adjusting chain” with the adjusting parameter – link-length $l_s=l_{CD}$.

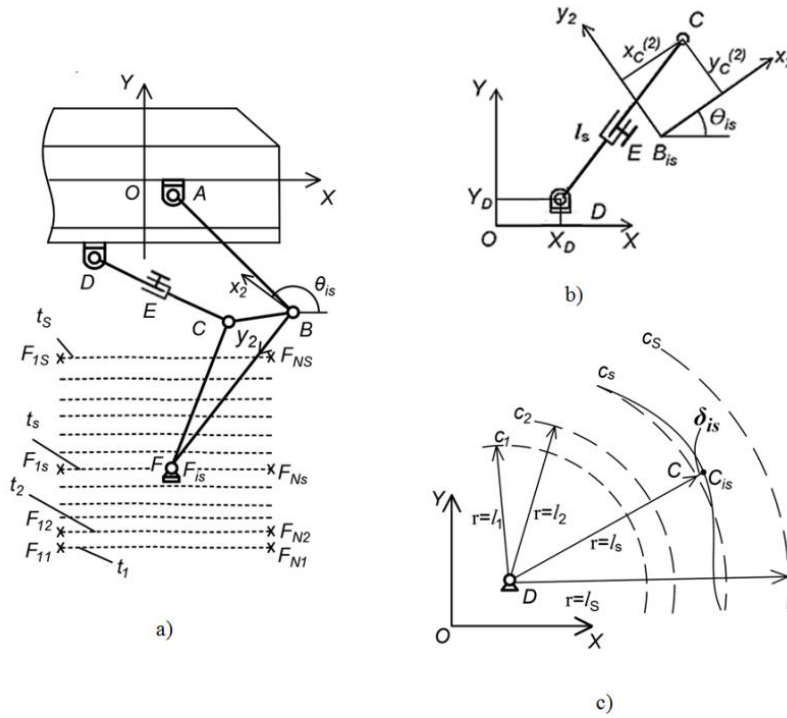

Fig.3. Adjustable four-bar leg mechanism and concentric circles fitting

The foot center F of the adjustable leg mechanism $ABC(E)D$ (Fig.3a) have to trace straight lines $t_s, s=1, \dots, S$, by adjusting link-length l_{CD} of link CD , so $l_{CD}=l_s$ have to be constant on each s -th trajectory. If each of the desired trajectories t_s are prescribed by N points $F_{is}, i=1, \dots, N, s=1, \dots, S$, then the output motion is given by the absolute coordinates $X_{F_{is}}, Y_{F_{is}}$ relative to the reference frame OXY . In first stage the variable chain ABF parameters $\mathbf{V} = [X_A, Y_A, l_{AB}, l_{BF}]^T$ are supposed to be specified by designer. Let Bx_2y_2 be the local coordinate system with the origin at joint center B and with the axis By_2 lying along the link BF (Fig.3a). As the dyad ABF parameters are known, the reference frame Bx_2y_2 positions relative to the reference frame OXY can be simply found by solving inverse kinematics for the dyad ABF . As mentioned above, if the mechanism $ABCD$ has to generate only one trajectory ($S=1$) then the mechanism synthesis is reduced to the traditional MMT problem of two-element link CD synthesis, that connects planes OXY and Bx_2y_2 : “circular point” C is sought on a plane Bx_2y_2 , this point traces approximately circular curve with respect to the reference frame OXY . Designing parameters in this case are: the local coordinates $x_C^{(2)}, y_C^{(2)}$ of point C on the plane Bx_2y_2 ,

the coordinates X_D, Y_D of the center D of this circle on the plane OXY and the circle radius $R=l_{CD}$. But in case $S>1$, when more than one trajectory have to be generated, then the moveable pivot C have to trace S concentric circular arcs with different radii $l_s, s=1, \dots, S$, but with the same center D (Fig.3b,c).

So we suppose on this stage that S sets of loci of the reference frame Bx_2y_2 relative to the reference frame OXY are known, each set specified by N positions $X_{B_{is}}, Y_{B_{is}}, \theta_{is}, i=1, \dots, N, s=1, \dots, S$. The absolute coordinates $X_{C_{is}}, Y_{C_{is}}$ of pivot C on the reference frame Bx_2y_2 are given by the local coordinates $x_C^{(2)}, y_C^{(2)}$ of pivot C in the reference frame Bx_2y_2 as follows

$$\begin{cases} X_{C_{is}} = X_{B_{is}} + x_C^{(2)} \cos \theta_{is} - y_C^{(2)} \sin \theta_{is} \\ Y_{C_{is}} = X_{B_{is}} + x_C^{(2)} \sin \theta_{is} + y_C^{(2)} \cos \theta_{is} \end{cases} \quad (1)$$

The main constraint equation is

$$\delta_{is} \equiv (X_{C_{is}} - X_D)^2 + (Y_{C_{is}} - Y_D)^2 - (l_{CD})_s^2 = 0 \quad (2)$$

This means that pivot C have to lie on concentric circles, here $(X_{C_{is}}, Y_{C_{is}})$ and (X_D, Y_D) are the coordinates of joint centers C and D in the reference frame OXY .

At the given quantities $X_{B_{is}}, Y_{B_{is}}, \theta_{is}, i=1, \dots, N, s=1, \dots, S$, the problem of synthesis consists in the determining of $(S+4)$ design parameters $X_D, Y_D, x_C^{(2)}, y_C^{(2)}, l_s, s=1, \dots, S$, which meet approximately constraint equations (2) for any $i=1, \dots, N, s=1, \dots, S$. The approximation error δ_{is} can be written as follows

$$\delta_{is} = -2X_{C_{is}} \cdot X_D - 2Y_{C_{is}} \cdot Y_D - (l_{CD})_s^2 + X_D^2 + Y_D^2 + X_{C_{is}}^2 + Y_{C_{is}}^2 \quad (3)$$

Thus, constraint equations (2) are reduced to $N \cdot S$ linear algebraic equations on $(S+2)$ variables $\mathbf{X} [x_1, \dots, x_S, x_{S+1}, x_{S+2}]^T$

$$x_s + a_{is} \cdot x_{S+1} + b_{is} \cdot x_{S+2} = c_{is} \quad (4)$$

$$x_s = \frac{1}{2}((l_{CD})_s^2 - X_D^2 - Y_D^2), x_{S+1} = X_D, x_{S+2} = Y_D \quad (5)$$

$$a_{is} = X_{C_{is}}, \quad b_{is} = Y_{C_{is}}, \quad c_{is} = \frac{1}{2}(X_{C_{is}}^2 + Y_{C_{is}}^2) \quad (6)$$

The equations (4) can be written in matrix form

$$\mathbf{AX} = \mathbf{b} \quad (7)$$

Here matrix $\mathbf{A} = [[\mathbf{H}_1][\mathbf{H}_2] \dots [\mathbf{H}_S]]$ depends on the rest design parameters $\mathbf{X}_1 = [x_C^{(2)}, y_C^{(2)}]^T$ and have dimensionalities $\dim \mathbf{A} = NS \times (S+2)$, $\dim \mathbf{b} = NS$, $\dim \mathbf{H}_s = (S+2) \times N$, the i -th column of the matrix \mathbf{H}_s is $\mathbf{h}_{is} = [\mathbf{e}_s^T, a_{is}, b_{is}]^T$. Vector \mathbf{e}_s is S -dimensional unit vector with the components $e_{\mu s} = \delta_{\mu}^s$, $\mu = 1, \dots, S$. Vector \mathbf{b} is NS -dimensional vector $\mathbf{b} = [\mathbf{b}_1^T, \mathbf{b}_2^T, \dots, \mathbf{b}_S^T]^T$, depending on parameters $\mathbf{X}_1 = [x_C^{(2)}, y_C^{(2)}]^T$, where $\mathbf{b}_s = [c_{1s}, c_{2s}, \dots, c_{Ns}]^T$; $s = 1, \dots, S$.

If the number of equations NS in (7) is greater than the number of unknowns $(S+2)$, then the approximate solution is

$$\mathbf{X}_0 = \mathbf{A}_p^{-1} \mathbf{b}, \quad (8)$$

where $\mathbf{A}_p^{-1} = [\mathbf{A}^T \mathbf{W}^T \mathbf{W} \mathbf{A}]^{-1} \mathbf{A}^T \mathbf{W}^T \mathbf{W}$ is “the left pseudo-inverse of \mathbf{A} ” [33], \mathbf{W} is the diagonal matrix $\text{diag}\{w_1, w_2, \dots, w_{NS}\}$ of weighting factors; $\dim \mathbf{W} = NS \times NS$. The solution \mathbf{X}_0 is the minimum of the Euclidean norm of the error $\boldsymbol{\delta} = \mathbf{AX} - \mathbf{b}$, so it is the solution of the following least-square approximation problem [18]

$$f \equiv \|\boldsymbol{\delta}\|_2^2 = \boldsymbol{\delta}^T \mathbf{W}^T \mathbf{W} \boldsymbol{\delta} \Rightarrow \min_{\mathbf{X}_1} \quad (9)$$

In order to determine the rest design parameters $\mathbf{X}_1 = [x_C^{(2)}, y_C^{(2)}]^T$ as well, the modified objective function is considered

$$f_1(\mathbf{X}_1) \equiv \min_{\mathbf{X}} f(\mathbf{X}_1, \mathbf{X}) = f^0(\mathbf{X}_1, \mathbf{X}_0(\mathbf{X}_1)) \Rightarrow \min_{\mathbf{X}_1} \quad (10)$$

taking into account, that matrix \mathbf{A} and vector \mathbf{b} in (7) depend on variables \mathbf{X}_1 and thus \mathbf{X}_0 is function of \mathbf{X}_1 as well

$$\mathbf{X}_0 = \mathbf{A}_p^{-1}(\mathbf{X}_1) \mathbf{b}(\mathbf{X}_1) \quad (11)$$

By this way the dimensionality of the source minimization problem is reduced from $(4+S)$ parameters down to just 2 variables $x_C^{(2)}, y_C^{(2)}$.

4. Numerical example

The desired horizontal paths are given within the square, which is specified by four vertexes $(-0.5; -2.0)$ and $(0.5; -2.0)$ relative to the reference frame OXY (Fig.4). Let foot center F have to trace along $S=10$ horizontal paths given by $N=10$ points F_{is} along each path, $i=1, \dots, N, s=1, \dots, S$. The variation range for the parameters $p_1=X_A, p_2=Y_A$ is specified as rectangle with vertexes $(-1.0; -1.0)$ and $(1.0; 0.0)$. The rest parameters $p_3=l_{AB}, p_4=l_{BF}, p_5=x_C^{(2)}, p_6=y_C^{(2)}$ are sought within the ranges: $0.5 \leq l_{AB} \leq 1.3, 0.5 \leq l_{BF} \leq 1.3, -0.5 \leq x_C^{(2)} \leq 0.5, -0.5 \leq y_C^{(2)} \leq 1.0$.

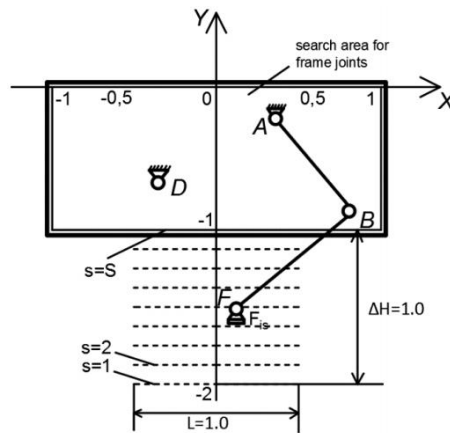

Fig.4 Workspace for leg foot and search area for frame joints

The initial guess for the parameters $\mathbf{P} = [p_1, p_2, \dots, p_6]^T$ was varied within the given range by using Sobol&Statnikov's random search technique [32]. As the result two local minimums determined by numerical optimization; 12 parameters $(l_{CD})_1, \dots, (l_{CD})_{10}, X_D, Y_D$ are calculated on each iteration using analytical solution (11). Numerical results are shown in Table 1, the mechanisms corresponding to these two local minimums are plotted in Fig.5.

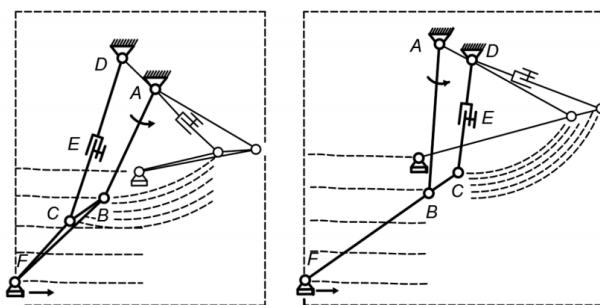

Fig.5 Adjustable leg mechanisms for multiple straight-line generation

Table 1. Mechanism dimensions

<i>Fig</i>	X_A	Y_A	AB	BF	$x_C^{(2)}$	$y_C^{(2)}$	X_D	Y_D	l_{CD} range	ε	η
5a	0,644	-0,316	1,024	1,047	0,048	0,337	0,357	-0,023	1,167÷1,497	2%	89,5%
5b	0,646	-0,044	1,249	1,271	0,014	-0,284	0,883	-0,151	1,196÷0,970	2,4%	100%

Both the adaptation range ΔH and accuracy ε are improved essentially. Parameter η is increased up to 89,5% and 100% instead of 16% in prototype, where $\eta = \frac{\Delta H}{L} 100\%$. The accuracy ε achieved 2% and 2,4% instead of 7% in prototype.

Conclusions

The problem of the approximate synthesis of the adjustable executive mechanism of the upper and lower limb exoskeleton with changeable link length is considered, when the foot point traces along horizontal straight lines on a plane. The method based on least square approximation allows to design the mechanism with no limitations on the number of desired paths and no limitations on the number of prescribed points on each path as well. Due to the proposed analytical solution the number of unknowns by numerical optimization is reduced essentially: from $(S+8)$ variables down to 6, where $S \geq 10$ is the number of given horizontal paths. Two local minimums of the optimization task are determined and thus the method allows to take full advantages from the considered mechanism structure. The adaptation range was increased up to 100% instead of 16% in prototype and the accuracy is improved down to 2% instead of 7%.

References

1. Ryan, A.D. and Hunt, K.H. (1985): Adjustable Straight-Line Linkages - Possible Legged-Vehicle Applications, Trans. ASME: J. Mechanisms, Transmissions and Automation in Design, Vol.107, pp.256-261.
2. Song S.M., Vohnout V.J., Waldron K.J. and Kinzel G.L. (1984): Computer-Aided Design of a Leg for an Energy Efficient Walking Machine. - Mechanisms and Machine Theory.- Vol.19, No.1, 1984.- pp.17-24.
3. Song, S.M. & Waldron, K.J. (1989): Machines that Walk: The Adaptive Suspension Vehicle. Cambridge, Mass: MIT Press.
4. Umnov, N.V. (1996): Peculiarities of Using Legged Mechanisms in Non-Traditional Vehicles. Encyclopedia of Machinery, Part 2, Vol.1, Chapter 11. – Moskow: Mashinostroenie Press, 1996 (in russian).

5. Xu, K., Liu H., Zhu, X. and Song, Y. (2019): Kinematic analysis of a novel planar six-bar bionic leg. – *Advances in Mechanism and Machine Science: Proc. of 15th IFToMM World Congress on Mechanism and Machine Science*, 2019, p.13-22.
6. Briskin, E.S., et al. (2018): Mathematical Modelling of Mobile Robot Motion with Propulsion Device of Discrete Interacting with the Support Surface. – 9th Vienna International Conference on Mathematical Modelling (MATHMOD 2018), Vienna, Austria, February 21-23, 2018, TU Wien, p. 259-264.
7. Komoda, K., Wagatsuma, H. (2017): Energy-efficiency comparisons and multibody dynamics analysis of legged robots with different closed-loop mechanisms. *Multibody System Dynamics*, 40(2), 2017, 123–153.
8. Ceccarelli, M. Historical and Modern Perspective of Walking Robots. 2016. www.academia.edu
9. Gavrilov, A.E., Golubev, D.V., Danshin, A.S. (2013): *Robotized Transport Platform with orthogonal legged mechanism*. – Journal “Izvestia of Volgograd State Technical University”, № 24(127), 2013 (in russian).
10. Plecnik, M., McCarthy, J. Design of Stephenson Linkages that wide a Point Along a Specified Trajectory. – *New Trends in Mechanism and Machine Science*, - Springer Netherlands, 2016, p.273 – 280.
11. Wang, C.Y., Hou, J.H. (2018) Analysis and Applications of Theo Jansen's Linkage Mechanism-Theo Jansen's Linkage Mechanism on Kinetic Architecture. Proceedings of the 23rd CAADRIA Conference, Tsinghua University, Beijing, China, pp.359–368.
12. Pop, F., Lovasz, E.C., Pop, C. et al. (2016) Dimensional synthesis of a leg mechanism. *Materials Science & Engineering Conference Series*, 147 (1), 012083.
13. Geonea, I., Tarnita, D., Carbone, G., & Ceccarelli, M. (2019). Design and Simulation of a Leg Exoskeleton Linkage for Human Motion Assistance. In *New Trends in Medical and Service Robotics*, 2019, Springer, Cham, pp. 93-100.
14. Kim, H., Jung, M., Shin, J and Seo, T. (2014): Optimal Design of Klann-linkage based Walking Mechanism for Amphibious Locomotion on Water and Ground. *Journal of Institute of Control, Robotics and Systems*. 20-9, 936-941